

- Ideal for robust applications.
- Low EMI/Self shielded design.
- Wide operating temperature range.
- Low DCR for cool operation.
- Designed for low ripple.
- Stable inductance over varying loads.
- Recommended by National Semiconductor® for use with LM259x and LM267x converters.

## Simple Switcher Specifications

Schott P/N	Previous Schott P/N	NSC Reference	Inductance $\mu$ H Min	Saturating Current Amps DC	Maximum DCR Ohms	Configuration
34529	67143910	L1	285	0.17	0.250	EP7 THD
34530	67143920	L2	183	0.19	0.200	EP7 THD
34531	67143930	L3	122	0.25	0.100	EP7 THD
34532	67143940	L4	83	0.30	0.075	EP7 THD
34533	67148310	L6	58	0.35	0.065	EP7 THD
34534	67148320	L8	41	0.40	0.035	EP7 THD
34535	67148330	L10	27	0.50	0.030	EP7 THD
34536	67143950	L5	375	0.30	0.700	EP7 THD
34537	67143960	L7	250	0.35	0.550	EP7 THD
34538	67143970	L9	173	0.45	0.300	EP7 THD
34539	67143980	L11	115	0.55	0.250	EP7 THD
34540	67143990	L12	78	0.70	0.200	EP7 THD
34541	67144000	L13	54	0.80	0.130	EP7 THD
34542	67148340	L14	38	1.10	0.075	EP7 THD
34543	67148350	L15	26	1.30	0.060	EP7 THD
34544	67148360	L16	18	1.60	0.050	EP7 THD
34545	67144030	L17	375	0.42	0.320	EP10 THD
34546	67144040	L18	250	0.51	0.220	EP10THD
34547	67144050	L19	173	0.63	0.180	EP10 THD
34548	67144060	L20	115	0.76	0.940	EP10 THD
34549	67144070	L21	78	0.95	0.070	EP10 THD
34550	67144080	L22	54	1.15	0.045	EP10 THD
34551	67144090	L23	38	1.37	0.034	EP10 THD
34552	67148370	L24	25	1.65	0.030	EP10 THD
34553	67148380	L25	18	2.00	0.021	EP10 THD
34554	67144100	L26	375	0.85	0.240	EP13 THD
34555	67144110	L27	250	1.00	0.150	EP13 THD
34556	67144120	L28	173	1.20	0.120	EP13 THD
34557	67144130	L29	115	1.50	0.090	EP13 THD
34558	67144140	L30	78	1.85	0.050	EP13 THD
34559	67144150	L31	54	2.25	0.350	EP13 THD
34560	67144160	L32	38	2.70	0.030	EP13 THD
34561	67148390	L33	25	3.50	0.024	EP13 THD
34562	67148400	L36	18	4.00	0.015	EP13 THD
34563	67144170	L37	250	1.70	0.180	EP17 THD
34564	67144180	L38	173	2.20	0.110	EP17 THD
34565	67144190	L39	115	2.50	0.070	EP17 THD
34566	67144200	L41	78	3.25	0.045	EP17 THD
34567	67144210	L44	54	3.70	0.040	EP17 THD
34568	67144220	L34	38	3.60	0.035	EP13 THD
34569	67144230	L35	26	3.70	0.025	EP13 THD
34571	67144240	L42	115	3.30	0.100	EP17 THD
34572	67144250	L43	68	3.50	0.060	EP17 THD

Parts availability subject to Schott manufacturing schedules and leadtimes. Not all parts available from stock. Please contact us for more details and availability. The Adobe Acrobat Reader is required to view these linked documents.

### Electrical Specifications Test Criteria

1. All inductors designed for operating at  $-40^{\circ}\text{C}$  to  $+130^{\circ}\text{C}$ .
2. Inductance is measured at 10 kHz, 0.1 Vrms.
3. Saturating current is the current at which the inductance is equal to a minimum of 90% of the rated value.
4. All terminals jumpered on each side of all parts.

All data is believed to be accurate at time of printing. Schott Corporation reserves the right to make changes without notification. "Schott" is a trade name of Schott Corporation. All other trademarks and trade names are the property of their respective holder.

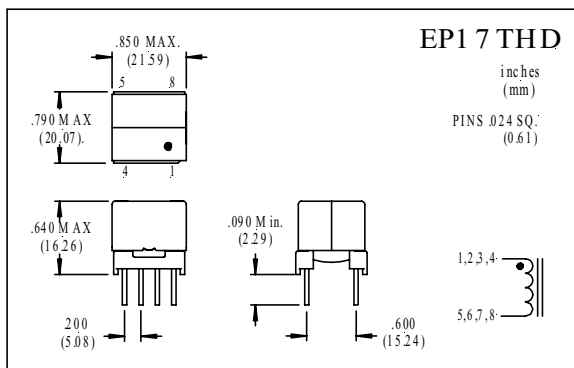
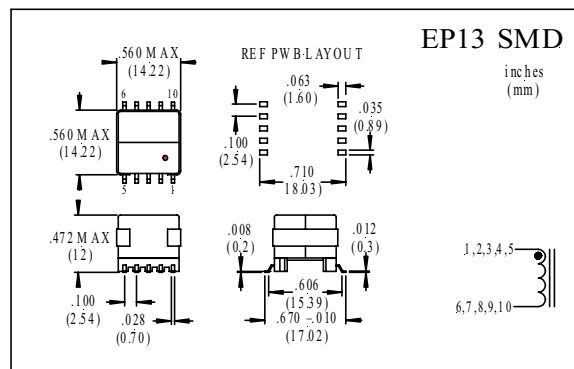
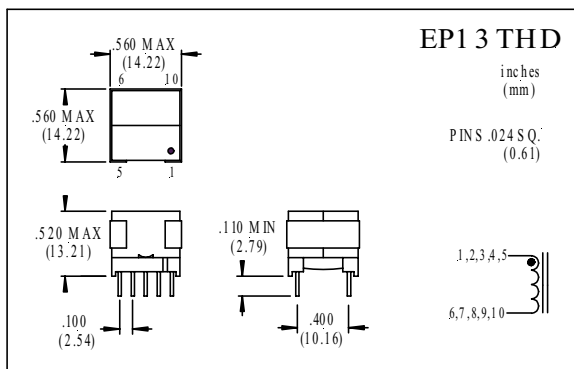
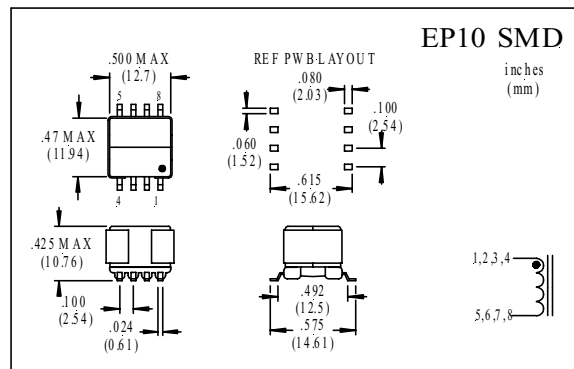
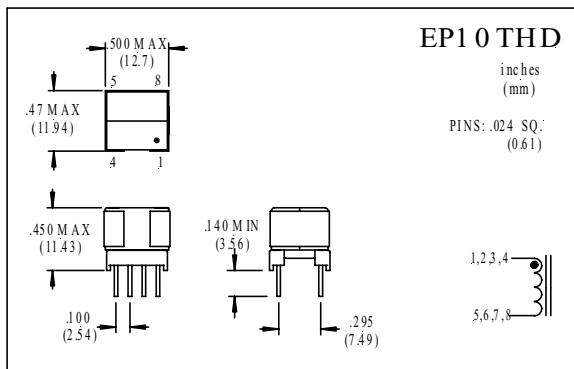
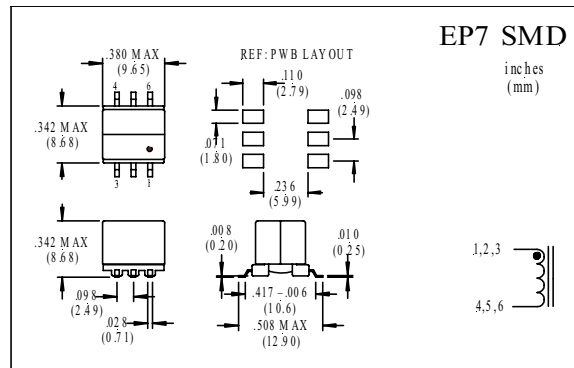
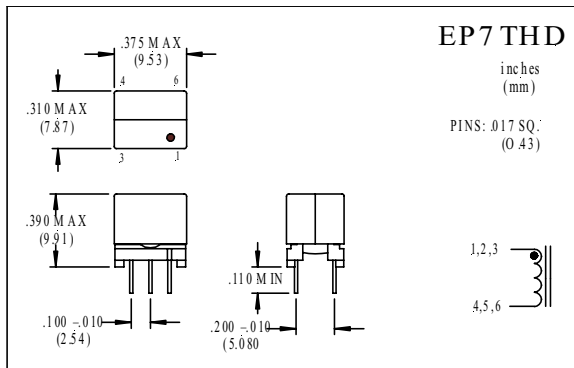

Schott Corporation  
 1000 Parkers Lake Road  
 Wayzata, Minnesota 55391  
 U.S.A.

Tel: + (952) 475-1173  
 Fax: + (952) 475-1786  
 Email: salesd@schottcorp.com  
 Web: http://www.schottcorp.com

All statements and technical information contained herein are believed to be accurate, but the accuracy and completeness thereof is not guaranteed. If any product is found to be defective, Schott Corporation's (Seller) only obligation shall be to replace such quantity of the product proved to be defective. User shall determine the suitability of the product for the intended use, and user assumes all risk and liability whatsoever in connection herewith. Seller shall not be liable for any direct, consequential, or incidental loss or damage. Conditions not specifically stated herein shall be governed by established trade customs. Schott Corporation reserves the right to make changes without notification. "Schott" is a trade name of Schott Corporation. All other trademarks and trade names are the property of their respective holder.